

BK-200A HHR-200A (OLD)

STANDARD TYPE
4/5A SIZE (HR17/43)

N type

DIMENSIONS (MM)

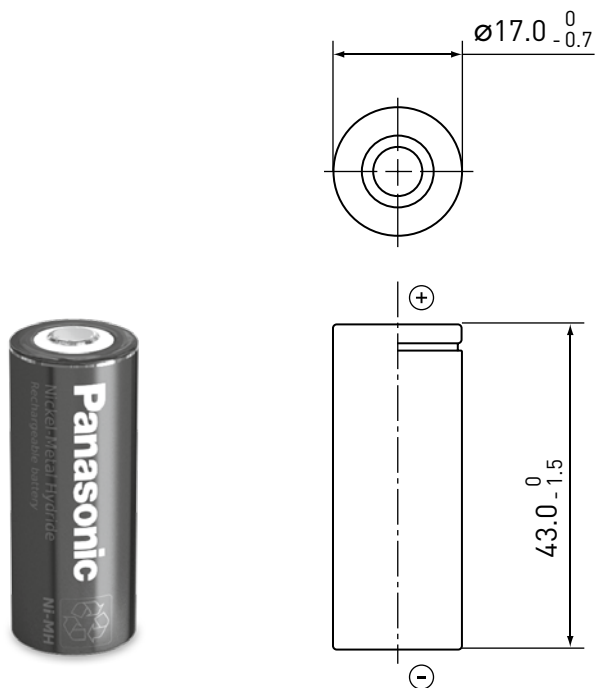

SPECIFICATIONS

Name	BK-200A	
Diameter (mm)	17.0 +0 / -0.7	
Height (mm)	43.0 +0 / -1.5	
Approximate weight (g)	32	
Nominal voltage (V)	1.2	
Discharge capacity*1	Average*2 (mAh)	2,040
	Rated/min. (mAh)	2,000
Approx. internal impedance at 1,000Hz at charged state (mΩ)	20	
Charge	Standard (mA x hrs.)	200 x 16
	Rapid*3 (mA x hrs.)	1,700 x 1.2
Ambient temperature	Charge	
	Discharge (°C)	
Storage	Standard (°C)	0 to +45
	Rapid (°C)	0 to +40
	<1 year	-20 to +35
	<6 months	-20 to +45
	<1 month	-20 to +55
	<1 week	-20 to +65

*1 After charging at 0.1It for 16 hours, discharging at 0.2It.

*2 For reference only.

*3 Need specially designed control system. Please contact Panasonic for details.

TYPICAL CHARGE CHARACTERISTICS

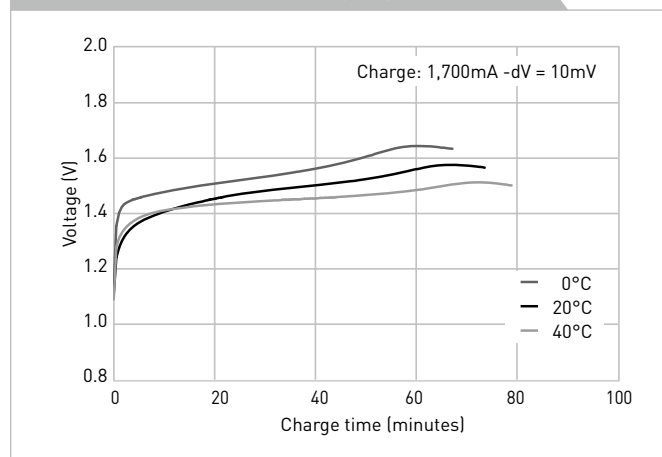

TYPICAL DISCHARGE CHARACTERISTICS

