



# NP6-7Ah

Valve-regulated lead-acid battery



## Characteristics

Nominal voltage		6V (3 cells per unit)
Nominal capacity at 20 hours rate/5.25V (25°C)		7Ah
Capacity (25°C)	10 Hours rate/5.25V	6.5Ah
	1 Hour rate/4.80V	4.2Ah
Terminal type		T1/T2
Torque		N/A
Approx. internal resistance (25°C)		16.0mΩ
Dimensions	Length	151±1.5mm (5.94inch)
	Width	34±1mm (1.34inch)
	Height	94±1mm (3.70inch)
	Total height	100±1mm (3.94inch)
Design Life (stand-by)	JIS at 25°C	5 years
	Eurobat at 20°C	3-5 years
Weight		1.10kg (2.42lbs)±5%
Nominal operating temperature		25±3°C (77°F±5)
Operating temperature range	Discharge	-15°C~50°C (5°F~122°F)
	Charge	-10°C~50°C (14°F~122°F)
	Storage	-20°C~50°C (-4°F~122°F)
Float charging voltage at 25°C		6.80V~6.90V
Cyclic charging voltage at 25°C		7.25V~7.50V
Temperature compensation	Float charge	-9 mV/°C/Block
	Cycle charge	-15 mV/°C/Block
Max. charging current (A)		2.1A
Max. discharge current for 5 seconds		105A
Self discharge rate (25°C)		≤3%/month
Battery container ABS UL94-HB		V-0 optional

## Construction

Component	Positive Plate	Negative plate	Container	Separator	Electrolyte	Safety valve	Terminal
Raw material	Lead dioxide	Lead	ABS	AGM	Sulfuric Acid	Rubber	Copper

## Constant current discharge characteristics at 25°C

(Ampere/battery)

F.V/Time	5min	10min	15min	30min	60min	2h	3h	4h	5h	10h	20h
4.80V	26.7	16.9	13.2	7.46	4.59	2.51	1.74	1.44	1.22	0.66	0.36
4.95V	25.9	16.4	12.9	7.31	4.52	2.49	1.72	1.43	1.21	0.66	0.35
5.10V	24.9	15.8	12.4	7.08	4.40	2.47	1.71	1.42	1.21	0.66	0.35
5.25V	23.8	15.1	12.0	6.91	4.31	2.43	1.70	1.41	1.20	0.65	0.35
5.40V	22.5	14.2	11.4	6.66	4.18	2.37	1.65	1.36	1.16	0.64	0.34

## Constant power discharge characteristics at 25°C

(Watts/battery)

F.V/Time	5min	10min	15min	30min	60min	2h	3h	4h	5h	10h	20h
4.80V	149	95.5	75.4	42.7	26.5	14.7	10.3	8.55	7.29	3.98	2.13
4.95V	145	92.7	73.6	41.9	26.1	14.6	10.2	8.50	7.25	3.96	2.12
5.10V	139	88.9	70.9	40.6	25.5	14.5	10.2	8.44	7.20	3.94	2.11
5.25V	133	85.0	68.5	39.6	25.0	14.2	10.1	8.38	7.15	3.92	2.10
5.40V	125	80.3	64.9	38.1	24.2	13.9	9.8	8.13	6.93	3.84	2.06

The above characteristics represent average values and can be obtained within three charge and discharge cycles. The batteries must be fully charged before testing. The data in this document is subject to change without notice and become contractual only after written confirmation. Please contact NPP Power for the latest available version.

## Overview



**WESTAR ENERGY** General Purpose series batteries are designed with state-of-the-art AGM (absorbent glass mat) technology, high-performance plates and electrolyte. With excellent value and characteristics, this range is suitable for all general purpose applications.

## Dimensions & Terminal Type (mm)

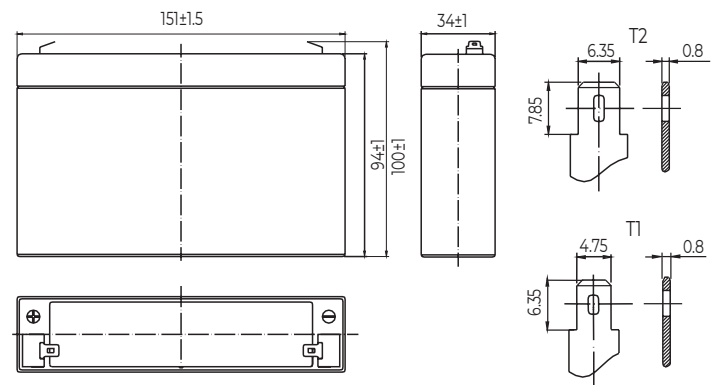

## Certification & Compliances



Compliant to: EUROBAT, RoHS, WEEE's and Reach.  
Manufactured according to IEC 60896-21 / 22

### Discharge characteristics (25°C)

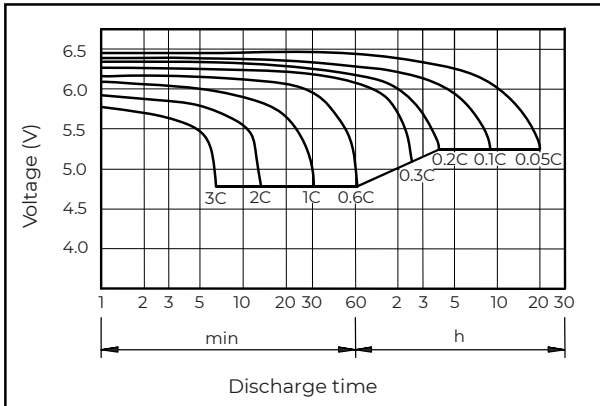

### Charging characteristics (25°C)

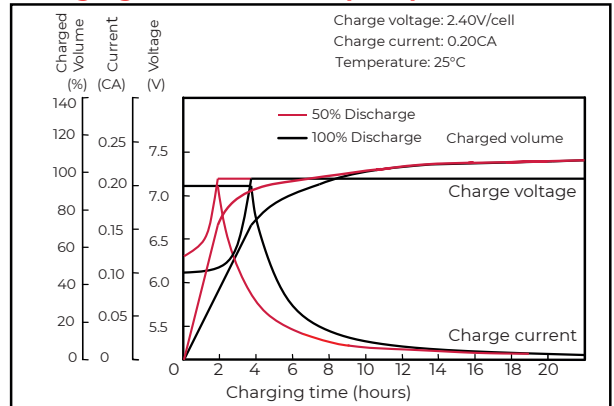

### Temperature effects on capacity

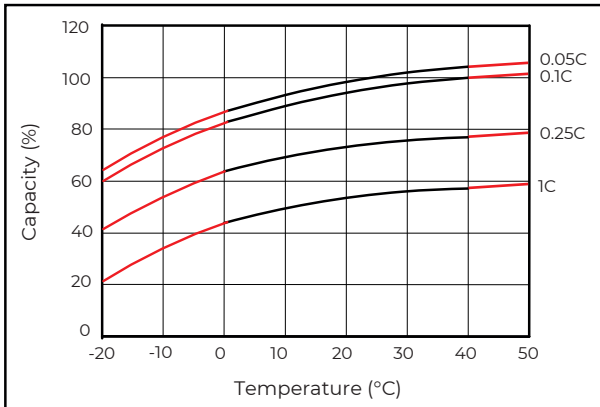

### Self-discharge characteristics

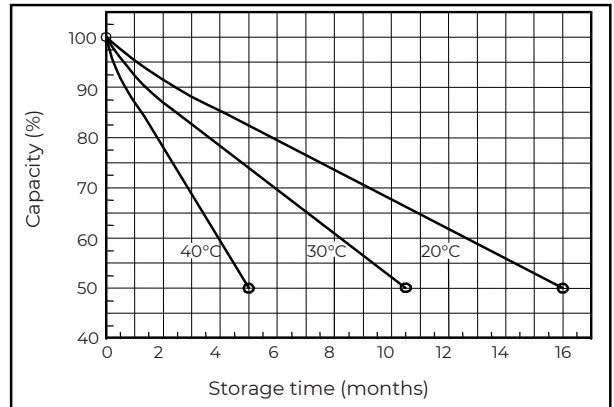

### Floating life on temperature

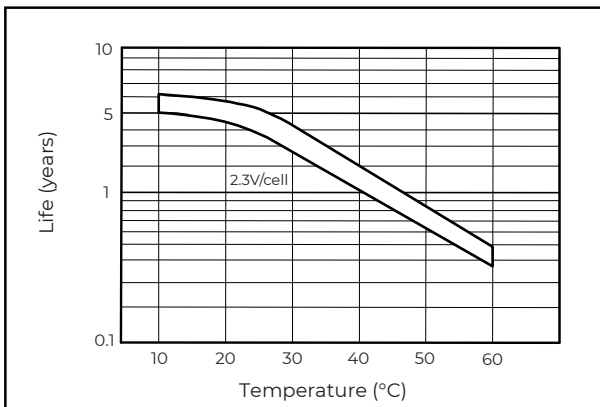

### Cycle life on D.O.D (25°C)

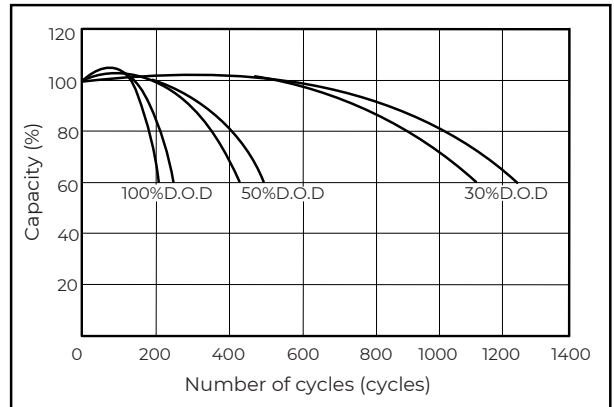

### Relationship for OCV and capacity (25°C)

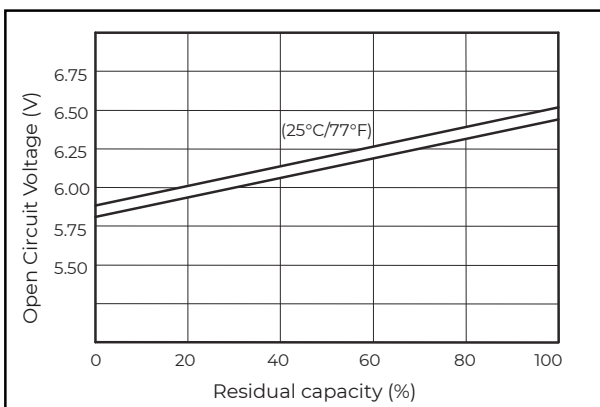

### Charging voltage VS temperature

