



FM12-1.3Ah

Valve-regulated lead-acid battery



Characteristics

Nominal voltage	12V (6 cells per unit)	
Nominal capacity at 20 hours rate/10.5V (25°C)	1.3Ah	
Capacity (25°C)	10 Hours rate/10.5V	1.1Ah
	5 Hours rate/10.5V	1Ah
Terminal type	T1	
Torque	N/A	
Approx. internal resistance (25°C)	90.0 mΩ	
Dimensions	Length	98±1mm (3.86inch)
	Width	43±1mm (1.69inch)
	Height	52±1mm (2.05inch)
	Total height	58±1mm (2.28inch)
Design Life (stand-by)	JIS at 25°C	5 years
	Eurobat at 20°C	3-5 years
Weight	0.54±5%	
Nominal operating temperature	25±3°C (77°F±5)	
Operating temperature range	Discharge	-15°C~50°C (5°F~122°F)
	Charge	-10°C~50°C (14°F~122°F)
	Storage	-20°C~50°C (-4°F~122°F)
Float charging voltage at 25°C	13.6V~13.8V	
Cyclic charging voltage at 25°C	14.5V~15.0V	
Temperature compensation	Float charge	-18 mV/°C/Block
	Cycle charge	-30 mV/°C/Block
Max. charging current (A)	0.36A	
Max. discharge current for 5 seconds	18A	
Self discharge rate (25°C)	≤3%/month	
Battery container ABS UL94-HB	V-0 optional	

Construction

Component	Positive Plate	Negative plate	Container	Separator	Electrolyte	Safety valve	Terminal
Raw material	Lead dioxide	Lead	ABS (V-0 opt.)	AGM	Sulfuric Acid	Rubber	Copper

Constant current discharge characteristics at 25°C

(Ampere/battery)

F.V/Time	5min	10min	15min	30min	60min	2hr	3hr	4hr	5hr	10hr	20hr
9.60V	4.58	2.90	2.27	1.28	0.79	0.43	0.30	0.25	0.21	0.11	0.06
9.90V	4.45	2.82	2.21	1.25	0.77	0.43	0.30	0.24	0.21	0.11	0.06
10.2V	4.26	2.70	2.13	1.21	0.75	0.42	0.29	0.24	0.21	0.11	0.06
10.5V	4.08	2.58	2.06	1.18	0.74	0.42	0.29	0.24	0.21	0.11	0.06
10.8V	3.85	2.44	1.95	1.14	0.72	0.41	0.28	0.23	0.20	0.11	0.06

Constant power discharge characteristics at 25°C

(Watts/battery)

F.V/Time	5min	10min	15min	30min	60min	2hr	3hr	4hr	5hr	10hr	20hr
9.60V	51.2	32.8	25.9	14.6	9.10	5.03	3.53	2.93	2.50	1.36	0.73
9.90V	49.6	31.8	25.2	14.4	8.97	5.00	3.51	2.91	2.48	1.36	0.73
10.2V	47.6	30.5	24.3	13.9	8.74	4.96	3.49	2.89	2.47	1.35	0.72
10.5V	45.5	29.2	23.5	13.6	8.56	4.88	3.46	2.87	2.45	1.34	0.72
10.8V	43.0	27.5	22.2	13.1	8.30	4.76	3.36	2.79	2.38	1.32	0.71

The above characteristics represent average values and can be obtained within three charge and discharge cycles. The batteries must be fully charged before testing. The data in this document is subject to change without notice and become contractual only after written confirmation. Please contact for the latest available version.

Overview



WESTAR ENERGY General Purpose series batteries are designed with state-of-the-art AGM (absorbent glass mat) technology, high-performance plates and electrolyte. With excellent value and characteristics, this range is suitable for all general purpose applications.

Dimensions & Terminal Type (mm)

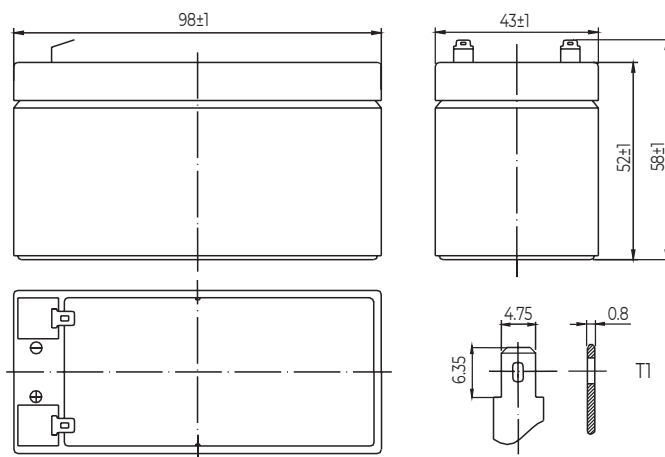

Certification & Compliances



Compliant to: EUROBAT, RoHS, WEEE's and Reach.
Manufactured according to IEC 60896-21 / 22