



FM12-12Ah

Valve-regulated lead-acid battery



Characteristics

Nominal voltage		12V (6 cell per unit)
Nominal capacity at 20 hours rate/10.5V (25°C)		12Ah
Capacity (25°C)	10 Hours rate/10.5V	11.2Ah
	5 Hours rate/10.5V	10.25Ah
Terminal type		T1/T2
Torque		N/A
Approx. internal resistance (25°C)		19.0 mΩ
Dimensions	Length	151±1.5mm (5.94inch)
	Width	98±1mm (3.86inch)
	Height	95±1mm (3.74inch)
	Total height	101±1mm (3.98inch)
Design Life (stand-by)	JIS at 25°C	5 years
	Eurobat at 20°C	3-5 years
Weight		3.40kg (7.51lbs)±4%
Nominal operating temperature		25±3°C (77°F±5)
Operating temperature range	Discharge	-15°C~50°C (5°F~122°F)
	Charge	-10°C~50°C (14°F~122°F)
	Storage	-20°C~50°C (-4°F~122°F)
Float charging voltage at 25°C		13.6V~13.8V
Cyclic charging voltage at 25°C		14.5V~15.0V
Temperature compensation	Float charge	-18 mV/°C/Block
	Cycle charge	-30 mV/°C/Block
Max. charging current (A)		3.6A
Max. discharge current for 5 seconds		180A
Self discharge rate (25°C)		≤3%/month
Battery container ABS UL94-HB		V-0 optional

Construction

Component	Positive Plate	Negative plate	Container	Separator	Electrolyte	Safety valve	Terminal
Raw material	Lead dioxide	Lead	ABS (V-0 opt.)	AGM	Sulfuric Acid	Rubber	Copper

Constant current discharge characteristics at 25°C

(Ampere/battery)

F.V/Time	5min	10min	15min	30min	60min	2hr	3hr	4hr	5hr	10hr	20hr
9.60V	45.8	29.0	22.7	12.8	7.86	4.30	2.97	2.46	2.09	1.14	0.61
9.90V	44.5	28.2	22.1	12.5	7.74	4.27	2.96	2.45	2.08	1.13	0.61
10.2V	42.6	27.0	21.3	12.1	7.55	4.24	2.94	2.43	2.07	1.13	0.60
10.5V	40.8	25.8	20.6	11.8	7.40	4.17	2.92	2.41	2.05	1.12	0.60
10.8V	38.5	24.4	19.5	11.4	7.17	4.07	2.83	2.34	1.99	1.10	0.59

Constant power discharge characteristics at 25°C

(Watts/battery)

F.V/Time	5min	10min	15min	30min	60min	2hr	3hr	4hr	5hr	10hr	20hr
9.60V	512	328	259	146	91.0	50.3	35.3	29.3	25.0	13.6	7.31
9.90V	496	318	252	144	89.7	50.0	35.1	29.1	24.8	13.6	7.28
10.2V	476	305	243	139	87.4	49.6	34.9	28.9	24.7	13.5	7.24
10.5V	455	292	235	136	85.6	48.8	34.6	28.7	24.5	13.4	7.20
10.8V	430	275	222	131	83.0	47.6	33.6	27.9	23.8	13.2	7.06

The above characteristics represent average values and can be obtained within three charge and discharge cycles. The batteries must be fully charged before testing. The data in this document is subject to change without notice and become contractual only after written confirmation. Please contact for the latest available version.

Overview



WESTAR ENERGY General Purpose series batteries are de-signed with state-of-the-art AGM (absorbent glass mat) technology, high-performance plates and electrolyte. With excellent value and characteristics, this range is suitable for all general purpose applications.

Dimensions & Terminal Type (mm)

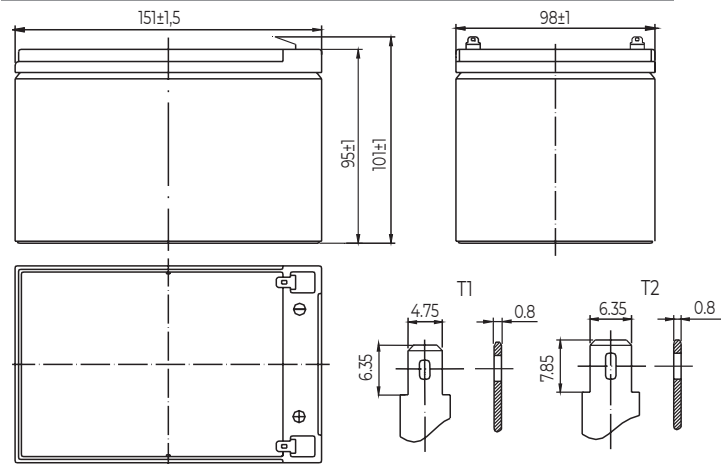

Certification & Compliances



Compliant to: EUROBAT, RoHS, WEEE's and Reach.
Manufactured according to IEC 60896-21 / 22

