



FM12-18Ah

Valve-regulated lead-acid battery



Characteristics

Nominal voltage		12V (6 cells per unit)
Nominal capacity at 20 hours rate/10.5V (25°C)		18Ah
Capacity (25°C)	10 Hours rate/10.5V	16.8Ah
	5 Hours rate/10.5V	15.4Ah
Terminal type		T3/T12
Torque		3.0±0.6N.m
Approx. internal resistance (25°C)		15.0mΩ
Dimensions	Length	181±2mm (7.13inch)
	Width	77±1mm (3.03inch)
	Height	167±2mm (6.57inch)
	Total height	167±2mm (6.57inch)
Design Life (stand-by)	JIS at 25°C	5 years
	Eurobat at 20°C	3-5 years
Weight		5.30kg (11.68lbs)±4%
Nominal operating temperature		25°C±3 (77±5°F)
Operating temperature range	Discharge	-15°C~50°C (5°F~122°F)
	Charge	-10°C~50°C (14°F~122°F)
	Storage	-20°C~50°C (-4°F~122°F)
Float charging voltage at 25°C		13.6V~13.8V
Cyclic charging voltage at 25°C		14.5V~15.0V
Temperature compensation	Float charge	-18 mV/°C/Block
	Cycle charge	-30 mV/°C/Block
Max. charging current (A)		5.4A
Max. discharge current for 5 seconds		270A
Self discharge rate (25°C)		≤3%/month
Battery container ABS UL94-HB		V-0 optional

Construction

Component	Positive Plate	Negative plate	Container	Separator	Electrolyte	Safety valve	Terminal
Raw material	Lead dioxide	Lead	ABS (V-0 opt.)	AGM	Sulfuric Acid	Rubber	Copper

Constant current discharge characteristics at 25°C

(Ampere/battery)

F.V/Time	5min	10min	15min	30min	60min	2h	3h	4h	5h	10h	20h
9.60V	68.8	43.6	34	19.2	11.8	6.45	4.46	3.69	3.14	1.70	0.91
9.90V	66.7	42.3	33.2	18.8	11.6	6.41	4.44	3.67	3.12	1.70	0.91
10.2V	63.9	40.5	32.0	18.2	11.3	6.35	4.40	3.64	3.10	1.69	0.91
10.5V	61.2	38.8	30.9	17.8	11.1	6.26	4.37	3.62	3.08	1.68	0.90
10.8V	57.8	36.6	29.3	17.1	10.8	6.10	4.24	3.51	2.99	1.65	0.88

Constant power discharge characteristics at 25°C

(Watts/battery)

F.V/Time	5min	10min	15min	30min	60min	2h	3h	4h	5h	10h	20h
9.60V	767	491	388	220	137	75.5	53.0	44.0	37.5	20.5	11.0
9.90V	744	477	379	215	134	75.0	52.7	43.7	37.3	20.4	10.9
10.2V	714	457	365	209	131	74.3	52.3	43.4	37.0	20.3	10.9
10.5V	683	437	352	204	128	73.2	52.0	43.1	36.8	20.2	10.8
10.8V	645	413	334	196	125	71.4	50.4	41.8	35.6	19.7	10.6

The above characteristics represent average values and can be obtained within three charge and discharge cycles. The batteries must be fully charged before testing. The data in this document is subject to change without notice and become contractual only after written confirmation. Please contact for the latest available version.

Overview



WESTAR ENERGY General Purpose series batteries are designed with state-of-the-art AGM (absorbent glass mat) technology, high-performance plates and electrolyte. With excellent value and characteristics, this range is suitable for all general purpose applications.

Dimensions & Terminal Type (mm)

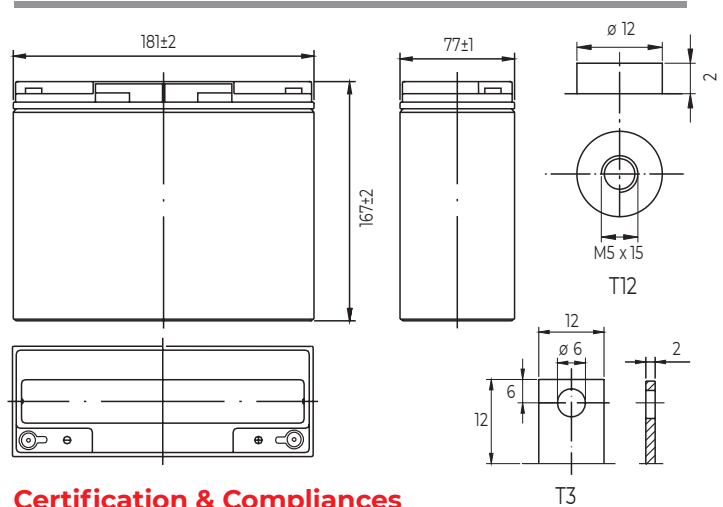

Certification & Compliances



Compliant to: EUROBAT, RoHS, WEEE's and Reach.
Manufactured according to IEC 60896-21 / 22